

# ROUGH TERRAIN STACKER - RT-S-62-AF

\*\*\* ANY ADDITIONS, DELETIONS, OR OMISSIONS MUST BE CORRECTED ON THIS DRAWING AS THIS DRAWING WILL BE CONSIDERED ALL INCLUSIVE \*\*\*  
 ALL GRAPHICS PROVIDED ARE FOR REFERENCE ONLY. IF CERTAIN DIMENSIONS ARE CRITICAL PLEASE VERIFY THOSE DIMENSIONS WITH YOUR SALESPERSON

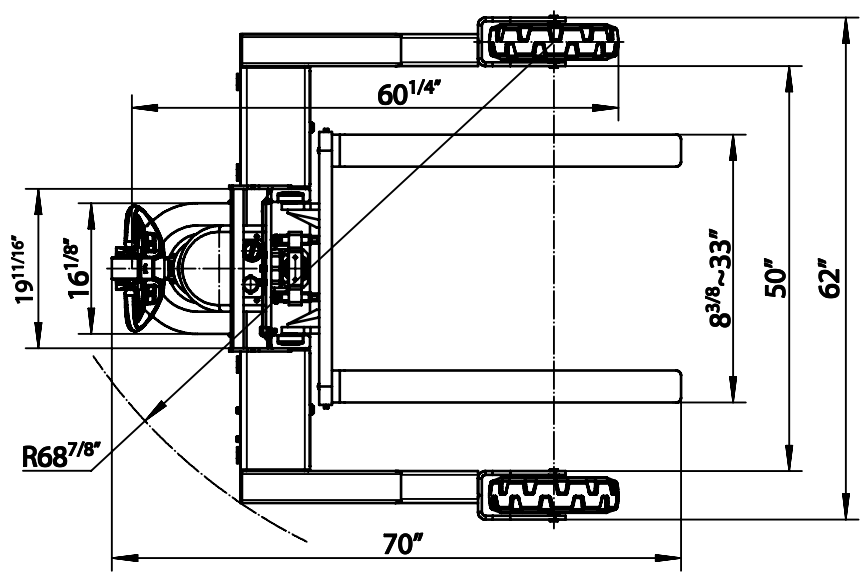
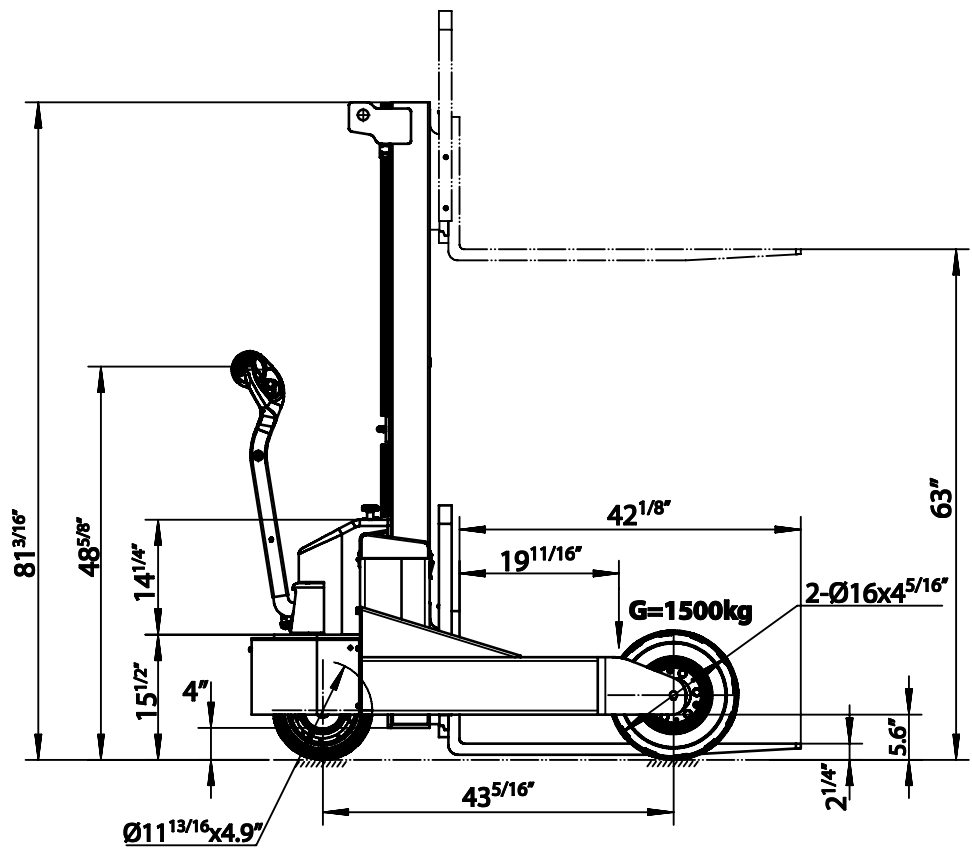

DIMENSION TOLERANCE ± 1/2"

## SPECIFICATIONS

- MODEL NO.: RT-S-62-AF
- CAPACITY: 3,000 LBS
- LIFT HEIGHT: 63"
- LOWERED HEIGHT: 2 1/4"
- DRIVE MOTOR AC16/1.5KW
- LIFT MOTOR: 24V/2.0KW
- BATTERY: 2x12V/105Ah
- BATTERY CHARGER: 24V/12amp
- TRAVEL SPEED W/O LOAD: 2.1m/h
- TRAVEL SPED W/ LOAD: 1.5m/h
- GRADEABILITY: 0°
- TOUGH BAKED IN POWDER COAT BLACK & YELLOW FINISH

**APPROVAL**

I, THE UNDERSIGNED, AGREE THAT THE PRODUCT AS REPRESENTED SATISFIES DESIGN AND DIMENSION REQUIREMENTS. I ALSO ACKNOWLEDGE MY DUTY TO CONFIRM PRODUCT AND INSTALLATION COMPLIANCE WITH ALL APPLICABLE FEDERAL, STATE AND LOCAL REGULATIONS AND STANDARDS.

**UNITS REQUIRING APPROVAL DRAWINGS OR MODIFIED ARE NON-RETURNABLE**

[ ] As drawn [ ] As marked

Signed: \_\_\_\_\_ Date: \_\_\_\_\_

Printed Name: \_\_\_\_\_

*LEAD TIME WILL START UPON RECEIPT OF SIGNED APPROVAL DRAWING*

DISTRIBUTOR'S NAME:		P.O.#
VESTIL MANUFACTURING		X
DRAWN BY: TM		DATE: 6/2/2020
REFERENCE: X		SALES: X
QUOTED LEAD TIME: X		SCALE: NTS
QUOTE # X		FILE NAME: RT-S-62-AF